

REVISION HISTORY

REV	DESCRIPTION	DATE	APPROVAL
A	Initial Release	12/04/08	J. Lee
B	Revise Current and Voltage	12/22/08	J. Lee
C	Revise input voltage level	12/29/08	J. Lee
D	Revise operating current & Volt	1/27/09	J. Lee

LEVEL OF PURCHASE	APPRV'D BY	DATE
RECORD AND FILE		
PRELIMINARY		
FINAL		

		DATE	<p>INSYNC Peripherals Corporation 22951 La Cadena Dr. Laguna Hills, CA 92653 Tel: 949-588-2675; Fax: 949-588-2679 Email: info@insyncperipherals.com</p> <p>2.0A LED Backlight Driver Series (Product Specification)</p>
DRAWN BY		12/22/08	
RELEASE BY			
ENGINEERING	J. Lee	12/22/08	
QA	Alan Phan	12/22/08	

SIZE A	CAGE CODE 1TWU7	DWG NO. 04-SPEC-239	REV. D
SCALE: NONE		SHEET 1 of 7	

2.0A LED Backlight Driver Series Product Specification

ORIGINATOR

DATE

SYSTEM ENGINEER

DATE

ENGINEERING PROGRAM MGR

DATE

Notice is hereby given that all data contained in, revealed by, or shown in this display document, whether a drawing or other writing, is proprietary and belongs to InSync Peripherals Corporation (IPC) of Laguna Hills, California. It is furnished and received in confidence solely for informational purposes of the recipient in connection with fulfilling actual or pending purchase or procurement contract between InSync and prospect buyers.

SIZE A	CAGE CODE 1TWU7	DWG NO. 04-SPEC-239	REV. D
SCALE : NONE			SHEET 2 OF 7

1.0	<u>SCOPE</u>	4
2.0	<u>APPLICABLE DOCUMENTS</u>	4
3.0	<u>REQUIREMENTS</u>	4
3.1	PRODUCT DEFINITION	4
4.0	<u>SPECIFICATION</u>	4
5.0	<u>MECHANICAL</u>	4
6.0	<u>INSPECTION</u>	6
6.1	QUALITY INSPECTION STANDARD	6
7.0	<u>RELIABILITY</u>	6
7.1	FAILURE REPORTING, ANALYSIS AND CORRECTIVE ACTION	6
8.0	<u>QUALITY ASSURANCE PROVISIONS</u>	6
8.1	GENERAL	6
8.2	RESPONSIBILITY	6
8.3	EXAMINATION OF PRODUCT	6
9.0	<u>PREPARATION FOR DELIVERY</u>	7
9.1	GENERAL	7
9.2	MARKING	7

SIZE A	CAGE CODE 1TWU7	DWG NO. 04-SPEC-239	REV. D
SCALE : NONE		SHEET 3 OF 7	

1.0 SCOPE

This specification establishes the performance and test requirements for a 2.0A LED backlight driver. This driver is designed to provide 2 outputs. Each output is a current source and is capable of sourcing current selectable ranging from +0.3A to +1.0A. It is used for high brightness display, sizes from 10.4 to 19” for outdoor and wide temperature applications. A separate part number shall be assigned to each driver corresponding to a given maximum drive current, such as from 0.30A to 01.0A. See note 1 below for part assignment.

2.0 APPLICABLE DOCUMENTS

The following documents, of the exact issue shown, form a part of this specification to the extent specified herein. In the event of a conflict between the documents referenced herein and the contents of this specification, the contents of this specification shall have precedence.

ANSI / IPC-A-610 Acceptability for Electronic Assemblies

ANSI / IPC-A-620 Requirements and Acceptance for Cable and Wire Harness Assemblies

IPC DOCUMENTS TBD

3.0 REQUIREMENTS

This driver is designed in accordance with this specification, including requirements covering all operating and non-operating conditions. The driver shall meet performance and all other requirements of this specification while installed in the intended equipment, provided the environment is no more severe than that specified herein.

3.1 PRODUCT DEFINITION

This driver includes the following.

- a. Driver (conformal coating optional)
- b. Input cable (optional)

See Figure on page 5 for mechanical dimensions.

4.0 SPECIFICATION

4.1 Input Voltage: +10.0VDC to +16.0VDC

4.2 Output Voltage: limited to maximum +25VDC

4.3 Output Current: Two output, each output is Selectable from, +0.3A to +0.8A in multiple steps (Note 1)

4.4 Dimming Ratio: TBD

4.5 Analog voltage Dimming Control: 0V to +5VDC; 0= Maximum Output Current; +5VDC Minimum Output Current.

4.5 Enable Control On=0V or float; Off=+5VDC to +12VDC

4.6 Efficiency: 85% at maximum load

4.7 Operating Temperature: -40C to +75C

4.8 Non-operating Temperature: -40C to +75C

Note 1: A separate part number shall be assigned to each driver. Each driver corresponds to a given maximum drive current. For example for 0.32A, the unit is adjusted to a maximum of 0.32A and the part number is assigned as 04-SPEC-239-0.32. Likewise 0.50A maximum current, the part number is assigned as 04-SPEC-239-0.50

5.0 MECHANICAL

SIZE A	CAGE CODE 1TWU7	DWG NO. 04-SPEC-239	REV. D
SCALE : NONE		SHEET 4 OF 7	

Driver Dimensions

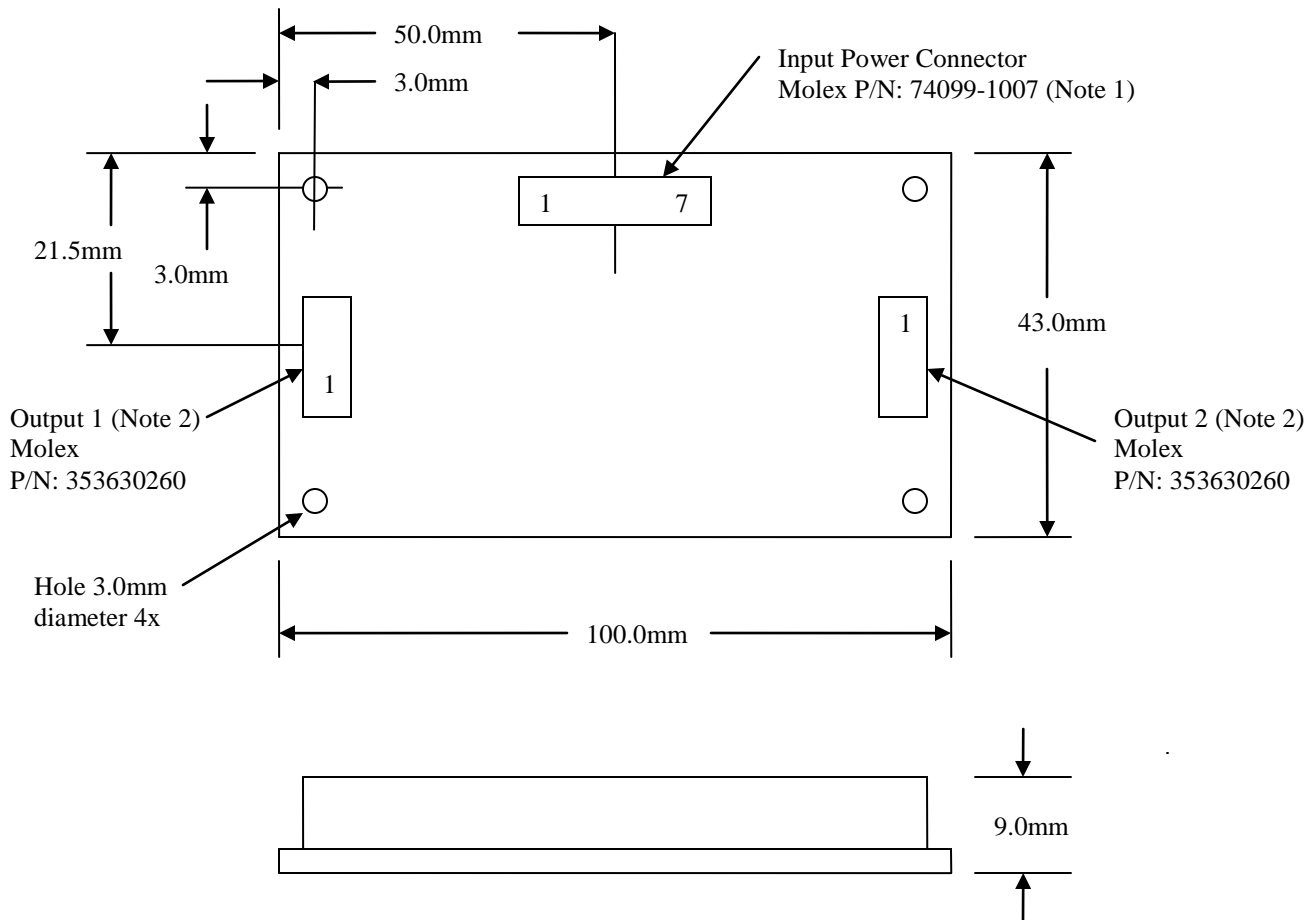

Notes (See Page 7 for Typical Application Diagram)

Input Connector

1. Pin1 and Pin 2= Input Voltage = +12.0VDC
Pin 3 and Pin 4=GND
Pin 5 Enable On=0V or Floating; Off= +5V to +12v
Pin 6 Dimming 0=Maximum ; +5V=Minimum Brightness
Pin 7 +5V Output

Output Connector

2. Pin 1 +25.0V DC output
Pin 2 Power Return
3. Output 1 and 2 mating connector housing is Molex 35507020; pin is Molex 50212800.
4. Input Power connector mating housing is Molex 50579407; pin will be Molex 16020082.
5. Mating cable for outputs 1 and 2 is UL1596AWG24.

SIZE A	CAGE CODE 1TWU7	DWG NO. 04-SPEC-239	REV. D
SCALE : NONE		SHEET 5 OF 7	

6.0 INSPECTION

6.1 Quality Inspection Standard

6.1.1 Inspection Criteria is based on Military Standard Mil-Std-105D.

6.1.2 Lot Size: 91 to 150

6.1.3 General Inspection Level: Level 1

6.1.4 AQL: 1.0

6.1.5 Sampling Plan: Single

6.1.6 Inspection: Normal

6.1.7 Sample Size: 8

6.1.8 AC=0; Re=1

7.0 RELIABILITY

7.1 FAILURE REPORTING ANALYSIS AND CORRECTIVE ACTION

IPC shall identify the root cause and corrective action of any driver failures that occur during the manufacture, test and deployment of the driver. IPC shall provide individual failure analysis for each driver returned to IPC as a result of a failure in the intended equipment. These analysis will list the symptoms of the failure, the root cause of the failure and the corrective action taken to prevent any reoccurrence.

8.0 QUALITY ASSURANCE PROVISIONS

8.1 GENERAL

The requirements for the formal verification of the performance, design, and construction of the driver shall be as specified in this section. The product must demonstrate its adequacy to meet the design/performance requirements of Section 4. Verification of each requirement shall be designated for accomplishment by analysis, inspection, demonstration or test, or combinations of these as specified herein. Verification methods are established as follows:

Test: An examination or trial which yields analytical data for use in comparing the measured performance with the specified requirement. Included are accept/reject criteria for comparison of test results with design requirements.

8.2 RESPONSIBILITY

Unless otherwise specified IPC is responsible for the performance of all verifications as specified herein. IPC may use its own or any other facilities suitable for the performance of tests and other verifications specified herein, unless disapproved by user. IPC reserves the right to perform any of the tests and other verifications set forth in the specification where such tests or verifications are deemed necessary to assure supplies and conform to prescribed requirements. IPC shall correct any design, material, or performance defect made evident during these tests.

8.3 EXAMINATION OF PRODUCT

Each driver shall be carefully examined to determine conformance to the requirements of this specification. Particular attention shall be given to workmanship, finish, dimensions, construction, cleanliness, identification and marking.

9.0 PREPARATION FOR DELIVERY

SIZE A	CAGE CODE 1TWU7	DWG NO. 04-SPEC-239	REV. D
SCALE : NONE			SHEET 6 OF 7

9.1 GENERAL

The driver shall be cleaned, preserved, packed, packaged, labeled, and marked in accordance with industry's standard commercial practices to protect from contamination and damage. The methods for cleaning, preserving, packing, packaging, labeling, and marking shall be subject to approval by the Buyer if it is specified in the Purchase Order.

9.2 MARKING

All parts and assemblies which require special care during packing, handling, or shipping shall be identified and marked appropriately. The driver shall be marked with at least the following information in such a manner that the marking will not be rendered illegible:

LED DRIVER
Insync Peripherals Corp.
949-588-2675
P/N: 04-SPEC-239-X.XX
Date Code: YYWW

Note: X.XX represents pre-adjusted maximum current.

Typical Application Diagram

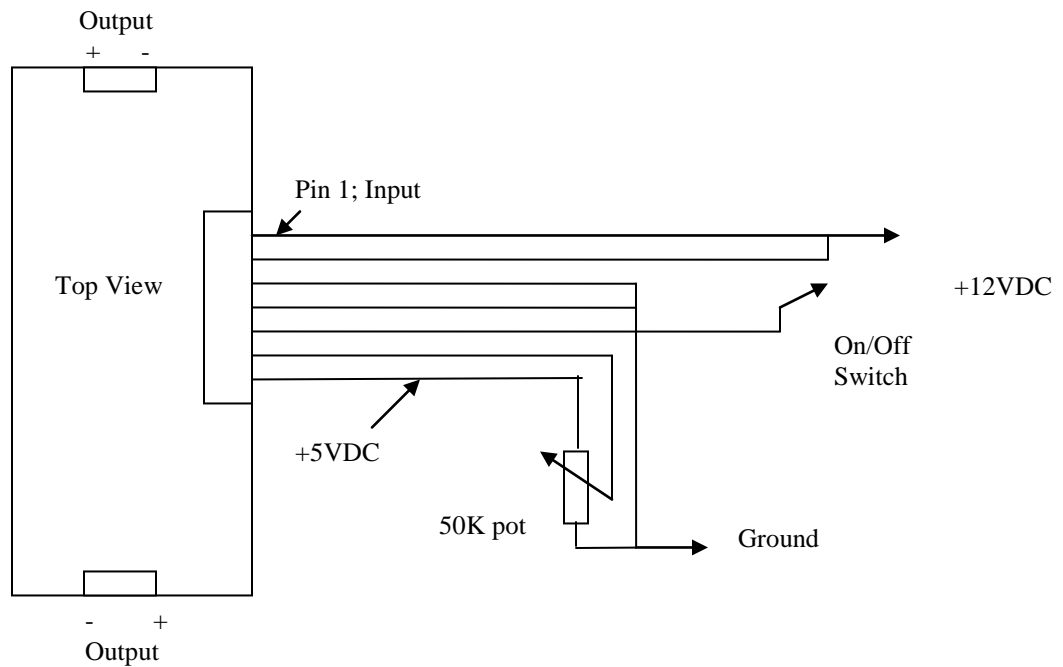

SIZE A	CAGE CODE 1TWU7	DWG NO. 04-SPEC-239	REV. D
SCALE : NONE		SHEET 7 OF 7	